

LL15.70

CAPACITY 230 KG

(2 persons 80x2=160 kg + tool box 70 kg)

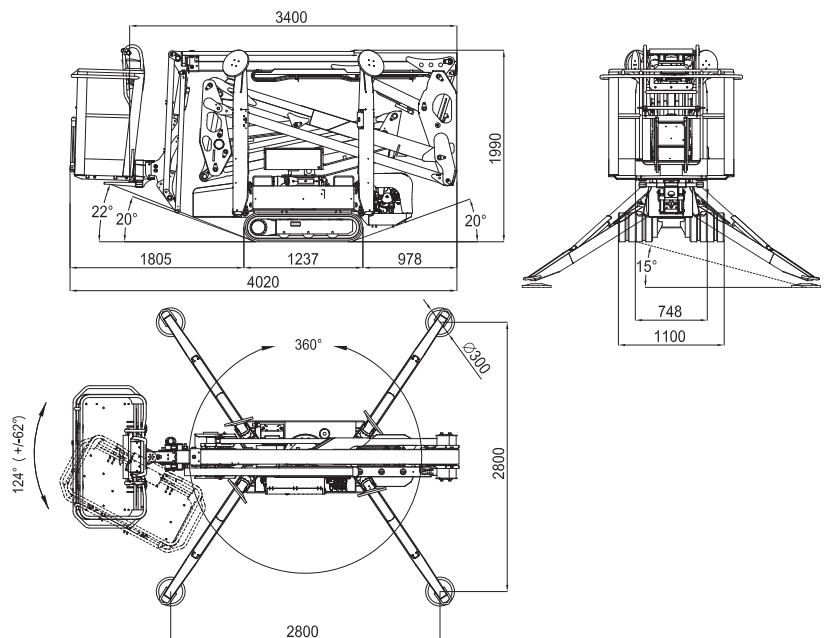
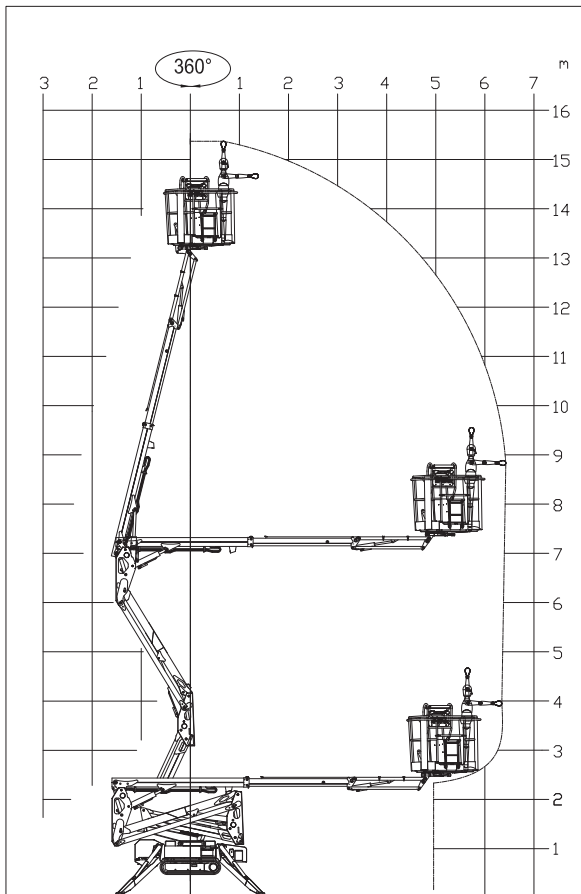

15,40 m



1.335 x 690 x h. 1.100 mm



2.800 x 2.800 mm



6,60 m



124° (+/-62°)



Automatic set up system IIS std.



4,02 m



16° / 28,7%



Remote control



3,40 m



748 - 1.100 mm



GPRS-GPS

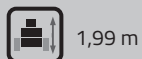

1,99 m



1.670 daN - 2,36 daN/cm²



R.A.H.M.



Lithium-ion battery pack
3,6 kWh
Optional



PETROL ENGINE

Brand.....HONDA
 TypeGX390
 Pistons no. and displacement.....
 single-cylinder 389 cm³
 Max gross power
 11,7HP - 8,7 kW @ 3600 rpm (GX390)
 Electrical start..... 12 volt

DIESEL ENGINE

Brand..... HATZ
 Type 1B40 - HD Autorev
 Pistons no. and displacement.....
 single-cylinder 462 cm³
 Max gross power
 10 HP - 7,5 kW @ 3600 rpm
 Electrical start..... 12 volt

LITHIUM-ION SYSTEM

Lithium-ion powered 3,6 kWh
 Onboard battery charger
 220V 50Hz or 110V 50Hz
 Autonomy..... 4-5 h
 Recharge time on flat batteries
4 h (indicative)
 Recharge time to 80% on flat batteries.
 2 h (indicative)

HYDRAULIC PUMPS

Electric motor no. 2 gear pumps

TRACKED UNDERCARRIAGE

Track tensioner grease-filled
 Rollers no. per side 3 + slide

Translation speed with 2nd auto2speed:

- thermal engine 1,4 - 2,6 km/h
 - lithium system..... 0,4 - 0,8 - 1,6 km/h

WEIGHT MACHINE petrol engine..... 1940 kg
 WEIGHT MACHINE diesel engine..... 1960 kg
 WEIGHT MACHINE lithium system 1992 kg

MAX WIND SPEED 12,5 m/s